

DUST & STATIC

5000 & 5100 IONISED AIR KNIVES

Ionised Air Knives produce fast-moving ionised air which can neutralise static electricity and remove contaminants.

They are used to clean plastic parts - removing the dust and eliminating the static electricity to prevent re-attraction.

- > Powerful ionisation kills the static charge holding the dust, allowing the fast beam of laminar air to remove it for a thorough cleaning.
- > The non-turbulent laminar airflow limits the recombination of ions in the air and so maximises the static neutralisation performance.
- > Compressed air is amplified by a factor of up to 20:1. So a litre of compressed air produces up to 20 litres of fast-moving air.
- > Available in a wide range of standard lengths in two body styles - the compact 5000 and the efficient 5100. See page 2 for further details.
- > The 1250 Static Eliminator Bar mounted on the air knife has market-leading reliability - see Datasheet on 1250 Static Eliminator for further details.
- > Simple to install and regulate.

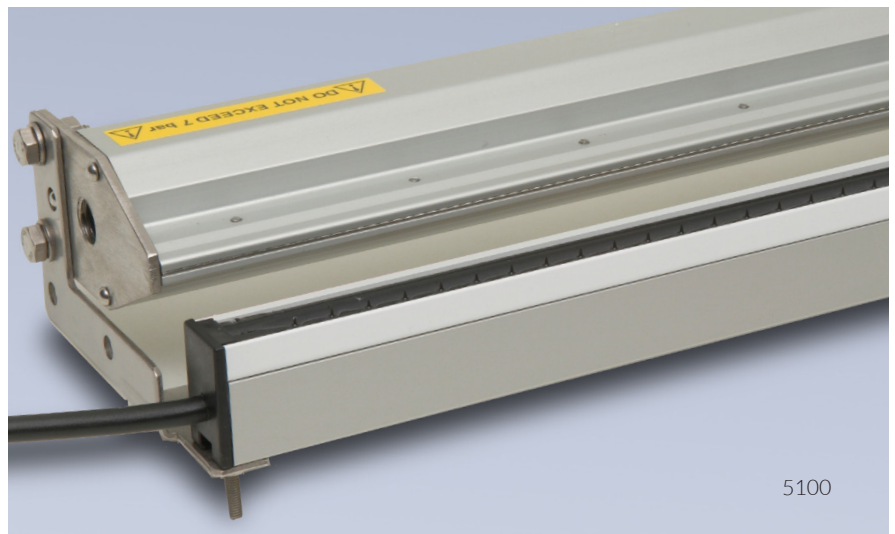

How it works:

Air is forced out of the slot at very high speed.

It sacrifices some of this speed to entrain ambient air to produce a large volume of fast-moving air.

The air is ionised as it passes over the static eliminator bar and so capable of neutralising static electricity.

The airspeed can be varied by adjusting the air pressure from 1 Bar up to 7 Bar. For example at 5 Bar pressure the airspeed at a distance of 150mm is 70m/sec. The best cleaning distance is between 100mm and 150mm.

The compressed air supply should be clean and dry.

To reduce air consumption we recommend that the airflow is controlled by a sensor so that it only blows when required.

Specification

Construction:	Aluminium air knife. 1250-S Static Eliminator Bar.
Length:	Available in standard sizes of : Model 5000: 150, 300, 450, 600, 750 and 900mm. Model 5100: 80, 100, 150, 200, 250, 300, 400, 450, 500, 600, 750, 800, 900, 1000, 1200 and 1300mm. Non standard up to 2.4m.
Cable:	2m HT cable is standard. Max cable length 10m.
Max. Temperature:	60°C.
Safety:	Meets OSHA and international standards. 5mA maximum current from Power Unit. High voltage resistance inside bars further limits current below 50µA.
Air:	The air should be clean and dry. Air connection(s): 1/4" BSP.
Power Unit:	Use with Fraser HP50 Power Unit.

Air Consumption

Pressure in Bar:	2	3	4	5	6	7
Air Consumption Lit/min per cm of Air Knife	19	22	27	33	39	45

The pipe work and air supply must be capable of supplying this volume of air.

Maximum pressure 7 Bar. Typical working pressure 5 Bar. We recommend that a sensor is used to minimise air consumption - blowing only when the product is present.

Dimensions:

5000 Compact Ionised Air Knife

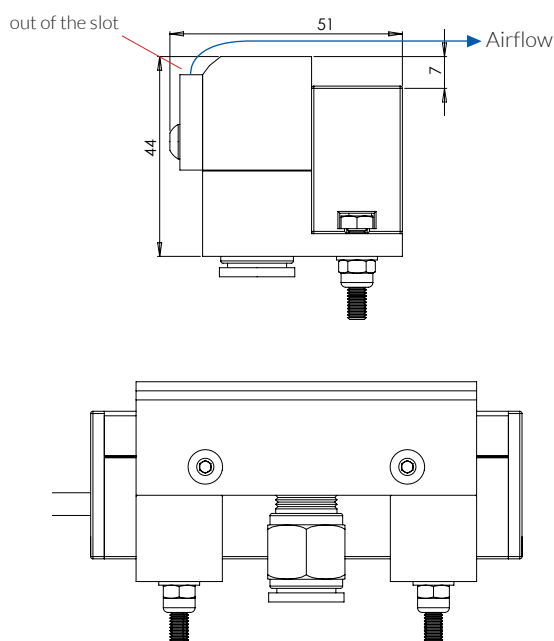

5100 Ionised Air Knife

